

TIMKEN**The Timken Company**

4500 Mt Pleasant St. NW

N. Canton, OH 44720

Phone: (234) 262-3000

E-Mail: CustomerCAD@timken.com • Web site: www.timken.com

Part Number 3204 AJ/2RS, Timken® Double Row Angular Contact Ball Bearings (3200, 3300)

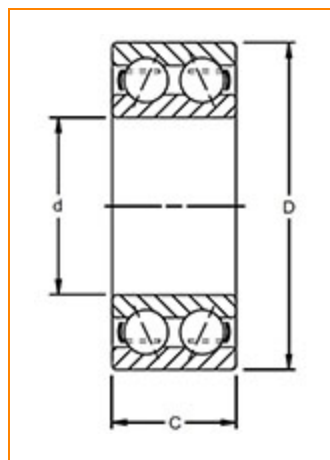

[Dimensions](#) | [Specifications](#) | [Basic Load Ratings](#) | [Abutment and Fillet Dimensions](#)

Dimensions

d - Bore	20.00 mm 0.7874 in
D - Outer Diameter	47.00 mm 1.8504 in
C - Ring Width	20.6 mm 0.8110 in
Contact Angle	30 °

Specifications

Features	Contact Seals
Ball Type	STEEL



Cage Type	Pressed
Cage Material	Steel
Bearing Weight	0.17 Kg 0.364 lb
Design Units	METRIC

Basic Load Ratings

C0 - Static Radial Rating	10400 N 2338 lbf
C1 ISO - Dynamic Radial Rating	15300 N 3439 lbf

Abutment and Fillet Dimensions

R - Inner Ring "To Clear" Radius ¹	1.00 mm 0.039 in
r - Outer Ring "To Clear" Radius ²	1.00 mm 0.039 in
da - Inner Ring Backing Diameter	25.6 mm 1.008 in
Da - Outer Ring Backing Diameter	41.4 mm 1.630 in

¹ Maximum housing fillet radius that bearing corners will clear.

² Maximum shaft fillet radius that bearing corners will clear.

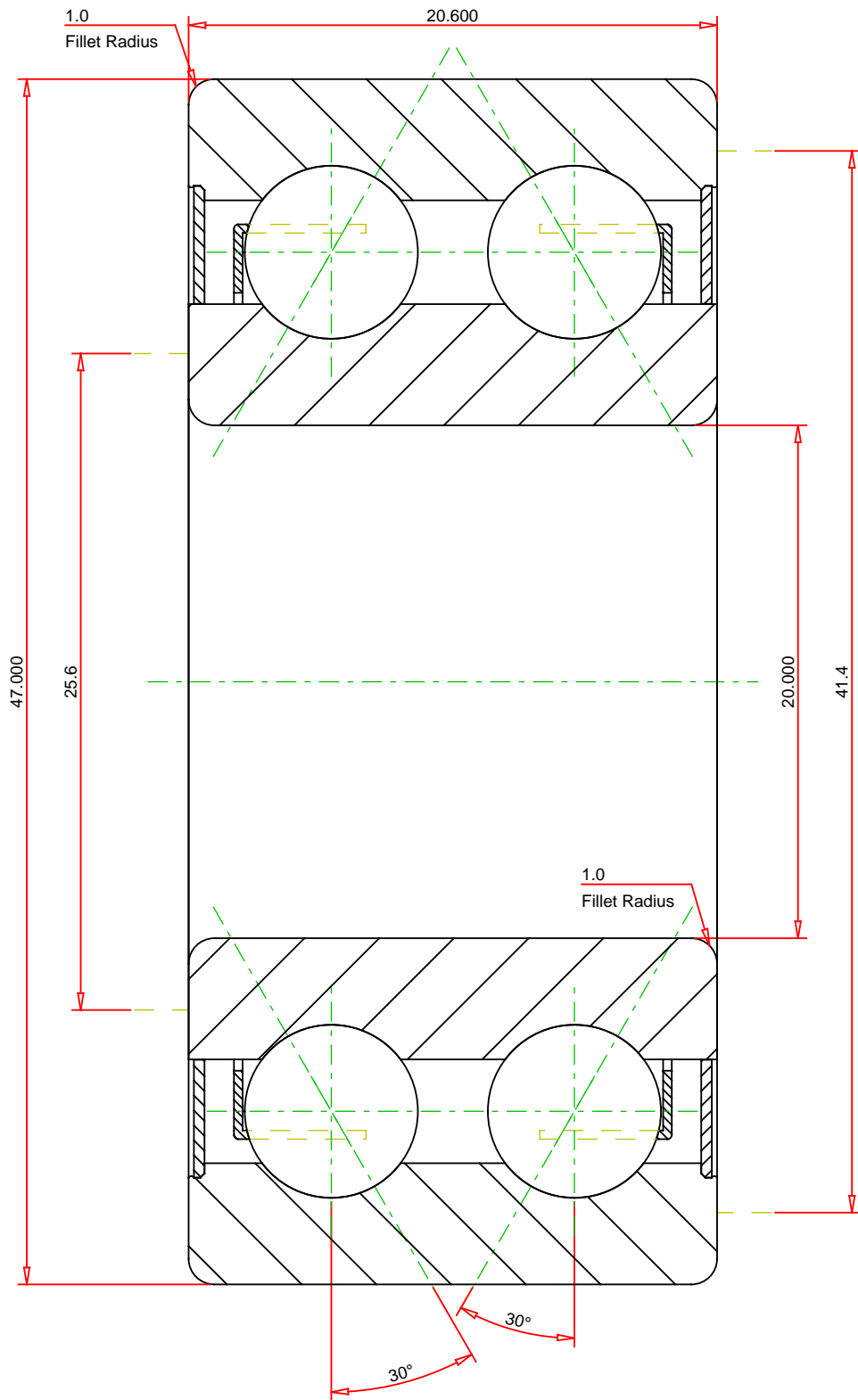

METRIC UNITS

Number of Balls Per Row 18
 Bearing Weight 0.170 kg

TIMKEN®

3204 AJ/2RS
 Timken® Double Row Angular Contact Ball Bearings
 (3200, 3300)

THE TIMKEN COMPANY
 NORTH CANTON, OHIO USA

Dynamic Load Rating 15300 N
 Static Load Rating 10400 N

Every reasonable effort has been made to ensure the accuracy of the information contained in this writing, but no liability is accepted for errors, omissions or for any other reason.

FOR DISCUSSION ONLY